



Development Services Department

Telephone (909) 931-4314

Facsimile (909) 931-4321

Supplemental Permit Information

As of May 20, 2009

TABLE OF CONTENTS

1.0 Permit Provisions

1.1 Permit Provisions

2.0 Ordinance

2.1 Ordinance 1841

3.0 Standards

3.1 W.26A and W.26B (Specifications for Water Department Easement Zone and Joint Trench Utilities)

Section 1.0

Permit Provisions

Permit Provisions

Page 1 of 2

- (1) The contractor shall provide and install barricades, delineators, warning devices, and construction signs in accordance with the approved traffic control plan. During adverse weather or unusual traffic or working conditions, additional traffic devices shall be placed as directed by the Engineer. All traffic control devices shall conform to Chapter 6 (Temporary Traffic Controls) of the current edition of the Manual on Uniform Traffic Control Devices (MUTCD) and California Supplement, unless otherwise approved by the Engineer.

The contractor shall relocate, preserve, and maintain the visibility of all existing signs within the project limits that affect the flow of traffic, as directed by the engineer. Any signs, which are damaged or found to be missing during the course of construction, shall be replaced by the contractor at his expense, as directed by the Engineer.

- (2) The City of Upland and its elected officials, officers, agents and employees shall not be answerable or accountable in any manner for any loss or damage that may happen to the work or any part thereof, or for any of the materials or other things used or employed in performing the work, or for injury or damage to any person or persons, either workmen, employees of the contractor or his subcontractors, or the public, or for damage to adjoining or other property from any cause whatsoever arising out of or in connection with the performance of the work. The contractor shall be responsible for any damage or injury to any person or property resulting from defects or obstructions or from any cause whatsoever, except the sole negligence or willful misconduct of City, its employees, servants, or independent contractors who are directly responsible to city during the progress of the work or at any time before its completion and final acceptance.

The contractor will indemnify City and its elected officials, officers, agents, and employees against and will hold and save them harmless from any and all actions, claims, damages to persons or property, penalties obligations, or liabilities that may be asserted or claimed by any person, firm, entity, corporation, political subdivision, or other organization arising out of or in connection with the work, operation, or activities of the contractor, his agents, employees, subcontractors, or invitees provided for herein, whether or not there is concurrent passive or active negligence on the part of the City, its elected officials, officers, agents and employees, but excluding such actions, claims, damages to persons or property, penalties, obligations, or liabilities arising from the sole negligence or willful misconduct of City, its employees, servants, or independent contractors who are directly responsible to city, and in connection therewith: the contractor will defend any action or actions filed in connection with any of said claims, damages, penalties, obligations, or liabilities and will pay all costs and expenses, including attorney's fees incurred in connection therewith.

- (3) The contractor shall not commence work under this contract until he has obtained all insurance required hereunder in a company or companies acceptable to City, nor shall the contractor allow any subcontractor to commence work on his subcontract until all insurance required of the subcontractor has been obtained. The contractor shall take out and maintain at all times during the life of this contract public liability insurance with liability limits of not less than \$1,000,000. Each such policy of insurance provided for herein shall: (a) name as additional insured the City of Upland, its elected officials, officers, agents, and employees, and any other parties specified in the bid documents to be so included; (b) specify that it acts as primary insurance and that no insurance held or owned by the designated additional insured shall be called upon to cover a loss under said policy; (c) contain a clause substantially in the following words: "it is hereby understood and agreed that this policy may not be canceled nor the amount of the coverage thereof reduced until thirty (30) days after receipt by city of a written notice of such cancellation or reduction of coverage as evidenced by receipt of a registered letter."

Permit Provisions

Page 2 of 2

- (4) It shall be the responsibility of the Permittee to notify the utility and irrigation companies before starting any work which may involve their facilities, and to make all necessary arrangements therewith, including any payments required for removal or relocation work necessary.
- (5) The contractor shall obtain a permit from the State of California, Department of Industrial Relations, Division of Industrial Safety, before starting the excavation of any trench five feet or more in depth. Shoring, bracing, sloping, and all other provisions for worker protection shall conform to the provisions contained in Article 6 of the State of California, Department of Industrial Relations Construction Safety Orders, effective August 8, 1965, and as amended July 27, 1973. If a variation from these standards is desired, a detailed plan shall be prepared by a registered civil engineer and submitted to the City Engineer for approval.
- (6) **A 48-HOUR ADVANCE NOTICE IS REQUIRED FOR INSPECTIONS PLEASE CALL (909) 291-2963.**
- (7) Material should not be ordered until forming and/or subgrade has been inspected and approved. Failure to obtain approval before placing material may result in rejection.
- (8) All workmanship and materials shall be guaranteed for a period of one year. Failure of the city inspector to detect flaws in work shall not relieve the Permittee of this responsibility.
- (9) **A COPY OF THE PERMIT SHALL BE KEPT AT THE WORKSITE.**

Special Conditions/Comments:

- City Water Division Standard W.26A and W.26B shall apply to this permit regarding separation requirements between utilities.
- The contractor is responsible to verify the location of all underground utility information supplied by the City or other utility companies before the commencement of work. The City of Upland is not responsible for the content or accuracy of record drawings.
- Contractor shall provide approved "As-Built" plans to the City Inspector before final acceptance.
- For any work in the public right-of-way, all contractors/sub-contractors that do not have a Class A State License, must obtain approval from Development Services before commencing any work under this permit.
- Any damages to parkway features (i.e., sprinkler systems, mailboxes, walkway pavers, etc.) shall be restored to the satisfaction of the Public Works Director
- Contractor shall maintain access to all businesses/residences at all times, unless otherwise approved by the Public Works Director.
- **ALL WORK SHALL BE COMPLETED MONDAY-FRIDAY BETWEEN THE HOURS OF 7:00 AM AND 6:00 PM.**

Section 2.0

Excavations in Pavement Ordinance

ORDINANCE NO. 1841

AN ORDINANCE OF THE CITY COUNCIL OF THE CITY OF UPLAND,
CALIFORNIA, AMENDING TITLE 12 OF THE UPLAND MUNICIPAL
CODE PERTAINING TO EXCAVATIONS IN PAVEMENT

THE CITY COUNCIL OF THE CITY OF UPLAND DOES HEREBY ORDAIN AS FOLLOWS:

I Intent of the City Council

(i) Untimely or improper excavations in paved streets owned and maintained by the City degrade and shorten the life of the roadway pavement;

(ii) Untimely or improper excavations in paved streets adversely impact the aesthetics of the community;

(iii) The City Council of the City of Upland desires to regulate excavations within the public right-of-way to ensure superior condition of the roadway pavement is preserved and maintained.

II Municipal Code Amendment

Section 1. Section 12.08.010 of Title 12 of the Upland Municipal Code shall be repealed in its entirety and replaced with the revised Section 12.08.010, which shall read, in words and figures, as follows:

"12.08.010 Grading, excavating, etc.

A. It is deemed unlawful for any person to make, suffer or to cause to be made any excavation in any public right-of-way or make any improvements on, under, over or across any street, alley or public place within, and under the jurisdiction and control of the City of Upland, without first obtaining from the City a permit authorizing such work.

No permit to excavate will be issued if the applicant does not have or has not demonstrated legal right or authority to occupy and use the public right-of-way for the purposes identified in the application.

B. Unless the street is identified in the City's then adopted Capital Improvement Program (CIP), excavations in any street, regardless of the street's age or condition, shall be subject to the following provisions:

1. The party responsible for making, suffering or causing the excavation to be made shall restore or cause to be restored such excavation in the manner specified herein:

i. For lateral cuts in the street:

a. Final resurfacing shall include the grinding of existing, surrounding pavement and repaving at a minimum depth of 0.15 feet. The applicant shall grind 5 feet on either side of the trench line for residential streets for the trench length, and 10 feet on either side of the trench for non-residential streets for the trench length.

b. Slurry seal shall be applied 30 feet on either side of the trench line for a length equivalent to the full width of residential streets, and for a length equivalent to the half width of non-residential streets.

c. If the distance between any two trenches, including the finished resurfacing area(s) as required herein and approved under permit, is less than 10 feet, the final resurfacing shall be extended to encompass the area between the trenches.

ii. For longitudinal cuts in the street:

- a. Final resurfacing shall include the grinding of existing, surrounding pavement and repaving at a minimum depth of 0.15 feet. The applicant shall grind 2 feet on either side of the trench line for residential streets, and the width of the affected travel lane(s) for non-residential streets. If the remainder pavement between the edge of cut and gutter lip is 48 inches or less, said pavement shall be included in the final resurfacing.
 - b. Slurry seal shall be applied for the full width of residential streets and half width of non-residential streets.
 - c. In all cases, the resurfacing shall be for the full length of the trench, but not less than 100 feet.
- iii. For trenches other than those that are longitudinal or lateral, the City Engineer shall establish the appropriate limits of paving in his sole reasonable discretion."

Section 2. Section 12.08.015 is hereby added to Title 12 of the Upland Municipal Code, to read, in words and figures, as follows:

"12.08.015 Excavations in New Pavement.

- A. No permit shall be issued which would permit an excavation, or pavement cut, in newly paved streets unless the applicant can demonstrate clearly to the City Engineer that the public health and safety require the contemplated work be permitted, and that there are no reasonable alternatives to cutting and/or excavating. This prohibition shall not apply to public agencies or public utilities when repairs are required to repair or replace failed pipelines and conduits, or when a new connection, which could not have been anticipated, must be made to satisfy a current need of that agency or utility.
- B. Newly paved streets are defined as those constructed, recently reconstructed, or repaved, with the improvements having been completed and accepted by the City not less than 60 months prior to the date of the request for cutting or excavation.
- C. If an installation or repair is demonstrated to be critically needed and no other alternatives exist, the City Engineer may approve an open cut or excavation within newly paved streets, subject to the following provisions:
 1. The party responsible for making, suffering or causing the cut or excavation shall restore or cause to be restored such cut or excavation in the manner specified herein:
 - i. For lateral cuts in the street:
 - a. Final resurfacing shall include the grinding of existing, surrounding pavement and repaving at a minimum depth of 0.15 feet. The applicant shall grind 10 feet on either side of the trench line for the full width of residential streets, and 20 feet on either side of the trench for the full width of non-residential streets.
 - b. Slurry seal shall be applied 50 feet on either side of the trench line, and for a length equivalent to the width of the street.
 - c. If the distance between any two trenches, including the finished resurfacing area(s) as required herein and approved under permit, is

less than 10 feet, the final resurfacing shall be extended to encompass the area between the trenches.

- ii. For longitudinal cuts in the street:
 - a. Final resurfacing shall include the grinding of existing, surrounding pavement and repaving at a minimum depth of 0.15 feet. The applicant shall grind the entire width of residential streets, and the half-street width between the curb and centerline (or raised median) for non-residential streets.
 - b. If there is no raised median, slurry seal shall be applied for the full width of non-residential streets.
 - c. In all cases, the resurfacing shall be for the full length of the trench, but not less than 1,000 feet.
- iii. For trenches other than those that are longitudinal or lateral, the City Engineer shall establish the appropriate limits of paving in his sole reasonable discretion."

Section 3. If any section, subsection, sentence, clause, phrase, or portion of this Ordinance is for any reason held to be invalid or unenforceable by a court of competent jurisdiction, the remaining portions of this Ordinance shall nonetheless remain in full force and effect. The Council of the City of Upland hereby declare that it would have adopted each section, subsection, sentence, clause, phrase, or portion of this Ordinance, irrespective of the fact that any one or more sections, subsections, sentences, clauses, phrases, or portions of this Ordinance be declared invalid or unenforceable.

PASSED, APPROVED AND ADOPTED this 23rd day of March, 2009.

John V. Pomierski, Mayor

ATTEST:

Stephanie A. Mendenhall, City Clerk

I, Stephanie A. Mendenhall, City Clerk of the City of Upland, California, do hereby certify that the foregoing Ordinance was introduced at a regular meeting of the City Council of the City of Upland held on the 9th day of March, 2009, and was adopted at a regular meeting of the City Council of the City of Upland on the 23rd day of March, 2009, by the following roll call vote:

AYES: Mayor Pomierski, Councilmembers Brandt, Musser, Thomas, Willis

NOES: None ABSENT: None ABSTAINED: None

Stephanie A. Mendenhall, City Clerk

Section 3.0

Standards

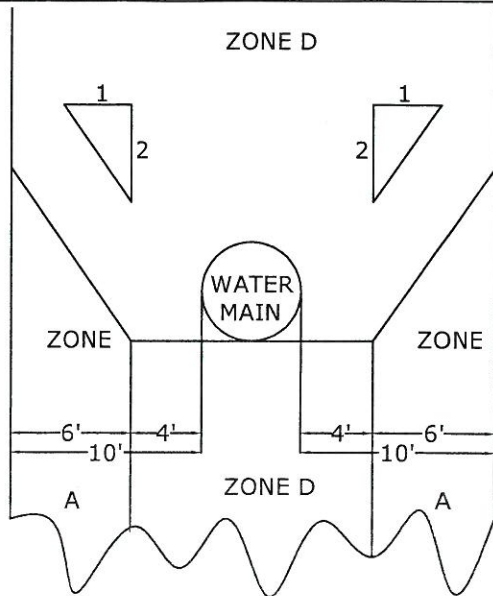

PARALLEL CONSTRUCTION

IF A MAIN LINE SEWER CANNOT BE LOCATED TEN OR MORE FEET FROM A PRESSURE WATER MAIN AND MUST BE LOCATED WITHIN ANY OF THE ABOVE INDICATED ZONES, SPECIAL CONSTRUCTION WILL BE REQUIRED AS SHOWN BELOW.

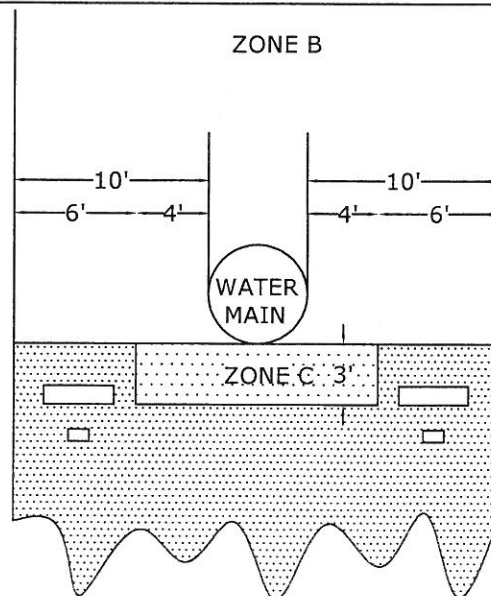

PERPENDICULAR COSTRUCTION

IF A MAIN LINE SEWER MUST CROSS A PRESSURE WATER MAIN WITHIN ANY OF THE ABOVE INDICATED ZONES, OR IS A HOUSE LATERAL MUST CROSS IN ZONE B, SPECIAL CONSTRUCTION WILL BE REQUIRED AS SHOWN BELOW.

ZONE	SEWER CONSTRUCTION REQUIREMENTS
A	V.C.P. WITH COMPRESSION JOINTS
B OR C	C.I.P. (CLASS 150) APPROVED MECHANICAL JOINTS, OR C.V.P. WITH SPECIAL CONCRETE ENCASEMENT PER (S-23 CASE IV), OR V.C.P. GROUTED IN CONTINUOUS STEEL CASING.
D	DO NOT LOCATED ANY PARALLEL SEWER IN THIS AREA WITHOUT HEALTH DEPARTMENT APPROVAL CALL MA 0-2980

FORCE MAINS:

PARALLEL CONSTRUCTION NOT PERMITTED IN ANY ZONE.

PERENDICULAR CONSTRUCTION IN ANY ZONE REQUIRES C.I.P. (CLASS 150) WITH APPROVED MECHANICAL JOINTS, OR ASBESTOS CEMENT PIPE WITH SPECIAL CONCRETE ENCASEMENT PER IV.

CASE IV-SPECIAL ENCASEMENT

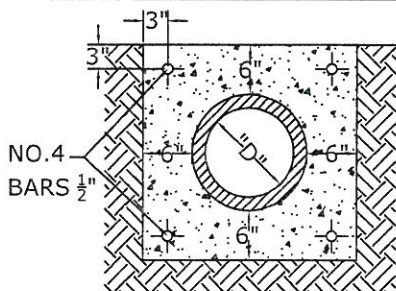

GENERAL NOTES:

1. EXTEND BOTH ENDS OF ENCASEMENT TO A POINT ONE INCH SHORT OF FIRST PIPE JOINT BEYOND LOCATIONS SPECIFIED ON PLAN.

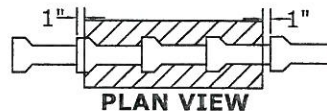

2. APPLY FORM OIL, THIN PLASTIC SHEET, OR OTHER ACCEPTABLE MATERIAL TO PIPE, TO PREVENT BOND BETWEEN PIPE AND CONCRETE.
3. USE CLASS 5C2500 CONCRETE FOR ALL CASES.

REVISION	DATE	UPLAND PUBLIC WATER DIVISION		DRAWING NUMBER
		PIPE ZONE		UPW-WD
NOT TO SCALE		APPROVED: <i>Anthony M. Co</i>	DATE: <i>3/16/09</i>	W.25

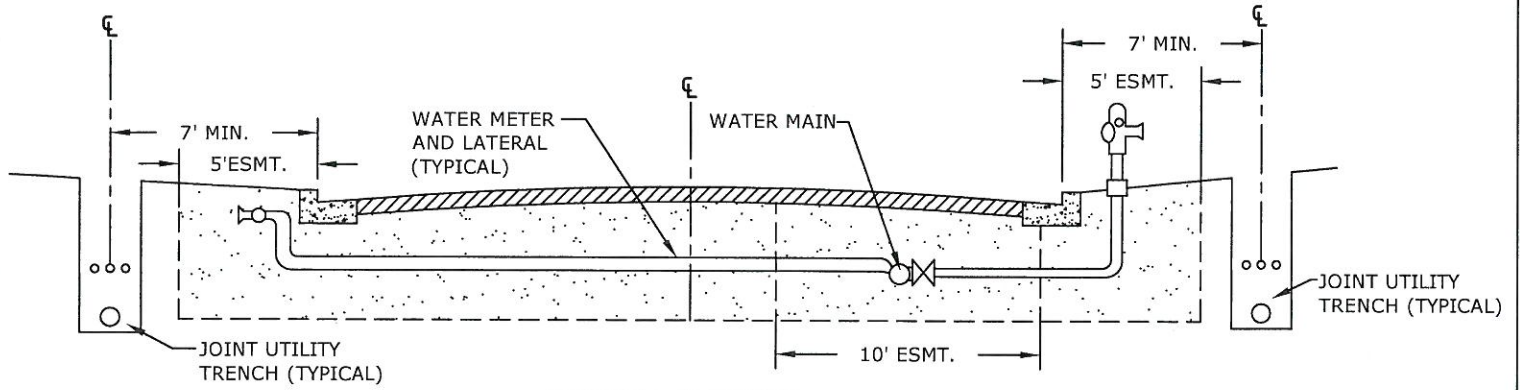

TYPICAL SECTION

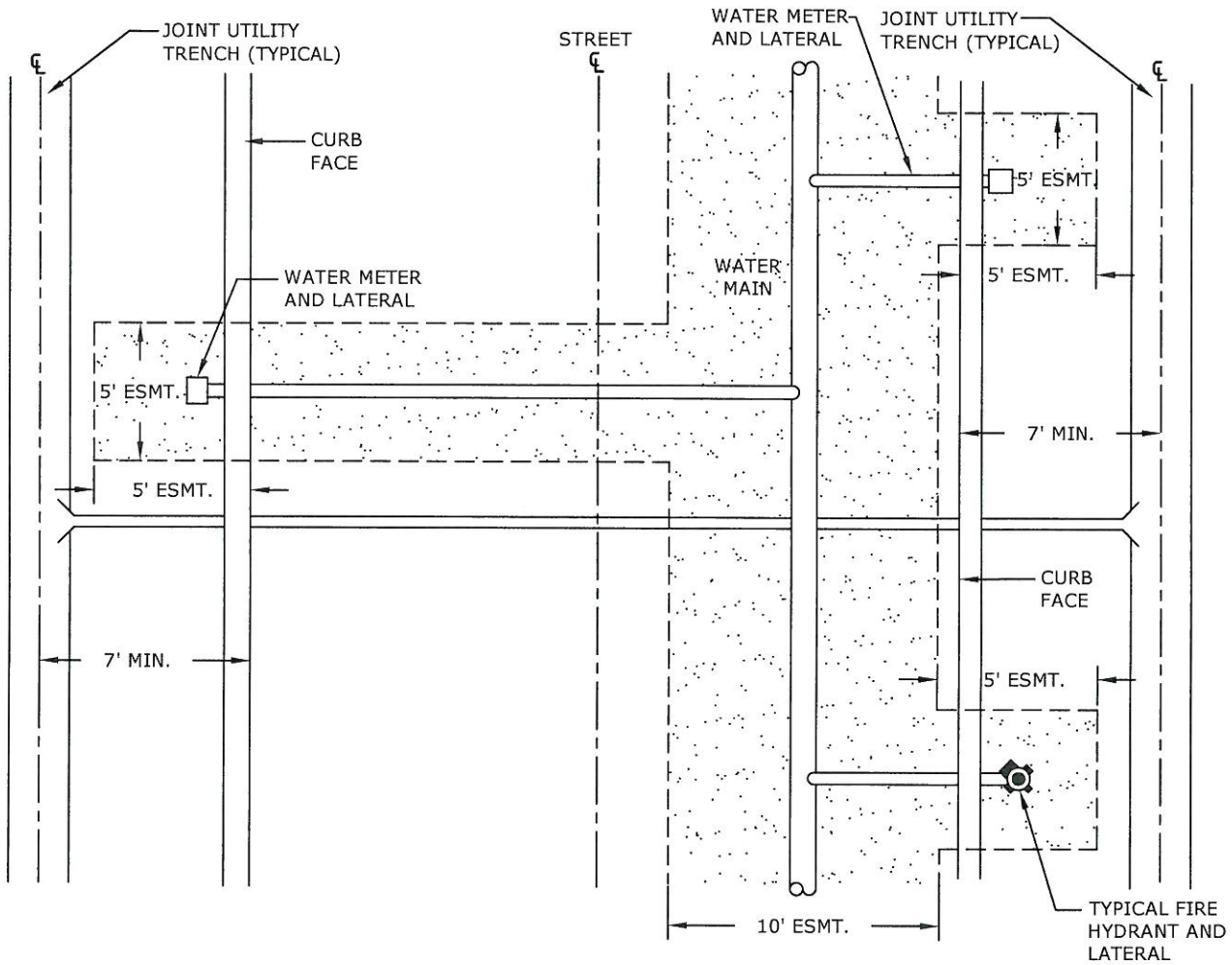

REVISION	DATE

UPLAND PUBLIC WATER DIVISION

DRAWING NUMBER

EASEMENT ZONE AND JOINT TRENCH UTILITIES

UPW-WD

W.26A

APPROVED: *[Signature]*

DATE: 7/16/09

NOT TO SCALE